

Electric Double Wall Oven

E30EW85GSS designer series



Wave-Touch® Controls

Sleek control panel illuminates with just a touch – giving you more control over your cooking – and fades away to an uncluttered display after an option is selected.



Smooth-Glide® Oven Racks

Ball bearing oven racks glide with unparalleled ease and extend fully for effortless access.



CustomConvect^{3™} Convection Technology

Distributes heat evenly throughout the oven by adding a third cooking element plus a variable speed fan.



Cool-Touch™ Oven Door

Beautiful all-glass door allows you to see what's inside and is cool to the touch and easy to clean.

30" ELECTRIC DOUBLE WALL OVEN

OVEN FEATURES

Upper Oven Cavity	4.2 Cu. Ft.
Lower Oven Cavity	4.2 Cu. Ft.
Cobalt Blue Interior	Yes
CustomConvect ^{3™} Convection System	Yes
Hidden Bake Element	Yes
Convection Conversion	Yes
Preheat Control	Yes
Keep Warm	Yes
Light Clean/Heavy Clean	Yes
Self-Cleaning with Auto-Safety Latch™	Yes
Self-Cleaning Cycle	Yes
Self-Cleaning Rack Removal Alert	Yes
Dual Radiant™ Baking System	Yes
Eight-Pass Broil & Radiant Bake Element	Yes
Smooth-Glide® Oven Racks	6
Standard Racks	2
Theatre Lighting	Yes
Porcelain Broiler Pan with Grill	Yes

CONTROL PANEL FEATURES

Electronic Oven Control	Yes
Electronic Clock/Timer	Yes
Electronic Temperature Display	Yes
Glass Wave-Touch® Control with Blue LED Display	Yes
Toggle Control	Yes
"My Favorite" Settings	Yes
Custom-Set™ Options with Temperature Probe	Yes
Automatic Oven – Delay, Cook & Off	Yes
Electronic Lockout	Yes
Automatic Oven Shutoff – 12 Hour	Yes
Auto Set™ Control – Convection	Yes
Programmable for °F or °C	Yes
Integrated Halogen Oven Light – Touch Pad	Yes

DOOR STYLE

Cool-Touch™ Oven Door	Yes
Removable Door	Yes
Oven Door Window	Extra Large
Stainless Door Handle/Towel Bar	Yes

ADDITIONAL FEATURES

Sabbath Mode (Star-K® Certified)	Yes
----------------------------------	-----

SPECIFICATIONS

Oven Cavity Dimensions –	
Height	16-1/2"
Width	24-1/8"
Depth	18-1/32"
Overall Exterior Dimensions –	
Height	52-9/16"
Width	30"
Depth (Including Door)	24-5/8"
(with 90° Door Open)	47-7/8"
Power Supply Location	Left Bottom Rear
Amps @ 240/208 Volts	33.3/28.9
Connected Load (kW Rating) @ 240/208 Volts	8.0/6.0
Bake Element (Watts @ 240/208 Volts)	2200
Broil Element (Watts @ 240/208 Volts)	4000
Armored Electrical Cable	Included
Shipping Weight (Approx.)	353 Lbs.

NOTE: Always consult local and national electric codes. Refer to Product Installation Guide for detailed installation instructions on the web at electroluxicon.com.

Specifications subject to change.

Electric Double Wall Oven

E30EW85GSS designer series

Electrolux | ICON®

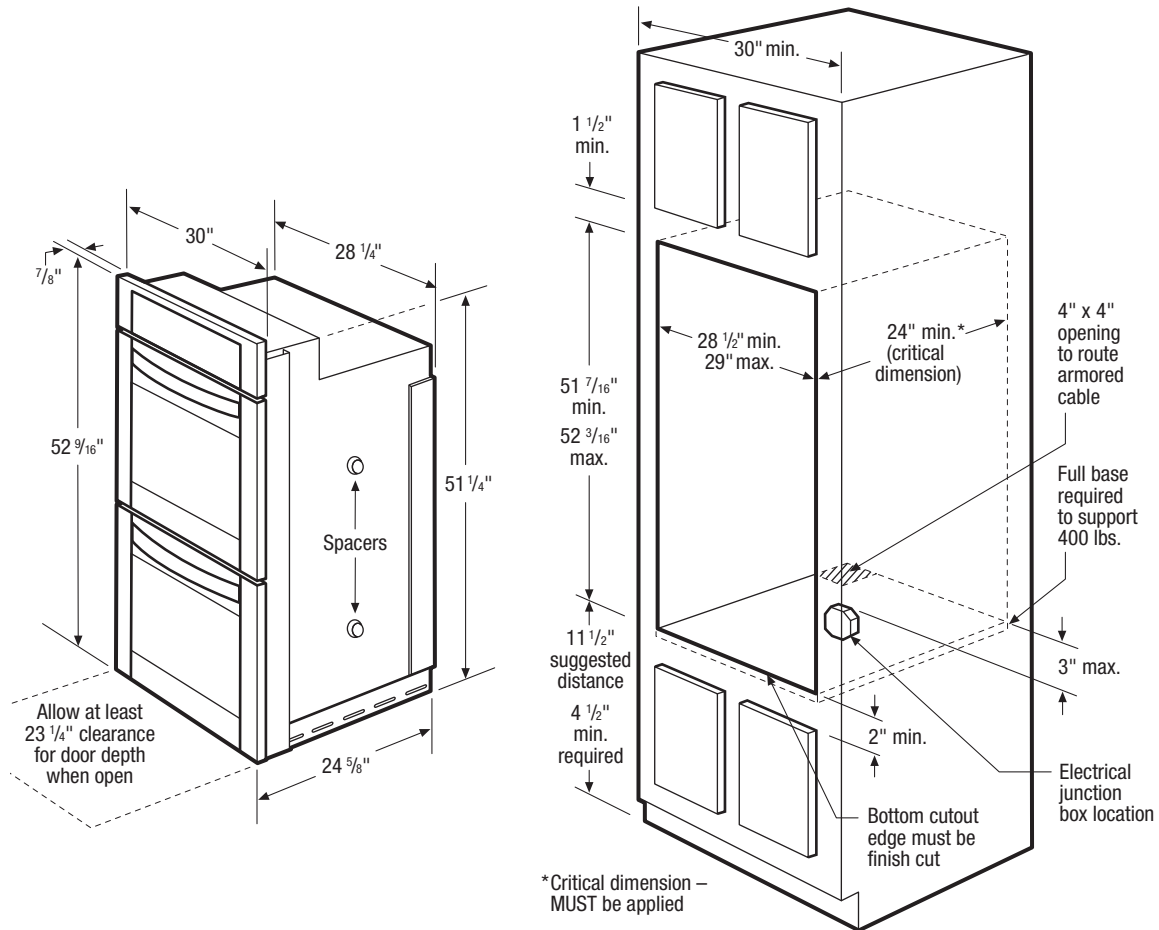

30" Electric Double Wall Oven Specifications

- Product Weight – 328 Lbs.
- Single phase 3- or 4-wire cable, 120/240 or 120/208 Volt, 60 Hertz AC only electrical supply with ground required on separate circuit fused on both sides of line.
- Connected Load (kW Rating) @ 240/208 Volts = 8.0/6.0kW
- Amps @ 240/208 Volts = 33.3/28.9 Amps
- Always consult local and national electric codes.
- Minimum 23-1/4" clearance for oven door depth when open.
- Suggested distance from floor is 11-1/2". Minimum required distance is 4-1/2".

- Minimum 24" deep cutout dimension is critical for proper installation, to ensure that oven's faceplate will fit flush against cabinet front.
- Full oven base of solid plywood or similar material required, capable of supporting 400 Lbs.
- Base must be level and cabinet front must be square with finish-cut bottom edge.
- Double Wall Ovens are NOT approved to be used in stackable or side-by-side installation.

Note: For planning purposes only. Refer to Product Installation Guide on the web at electroluxicon.com for detailed instructions.

Electrolux Major Appliances, N.A.

USA • 10200 David Taylor Drive • Charlotte, NC 28262 • 1-877-4electrolux (1-877-435-3287) • electroluxicon.com
 CANADA • 5855 Terry Fox Way • Mississauga, ON L5V 3E4 • 1-800-265-8352 • electroluxicon.ca

E30EW85GSS 04/11

© 2011 Electrolux Home Products, Inc.



High standards of quality at Electrolux Home Products, Inc. mean we are constantly working to improve our products. We reserve the right to change specifications or discontinue models without notice.

Printed in the U.S.A.

Use these dimensions and clearance instructions for planning purposes only. For detailed installation instructions, refer to installation guide, packed with product, or on the web at electroluxicon.com.

Front

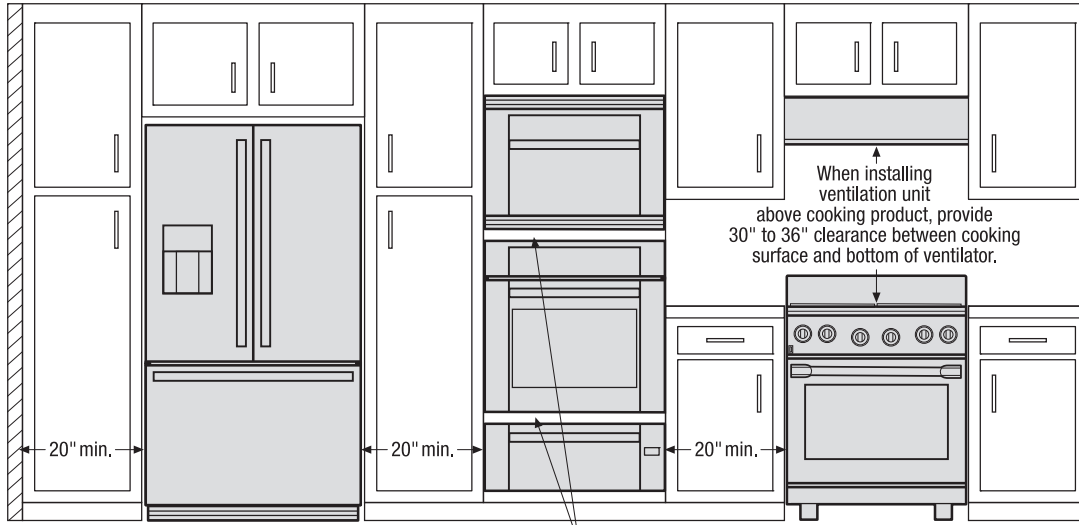

When installing appliances adjacent to each other, 20" minimum distance between each appliance required.

When installing built-in cooking appliances in combination, 2" minimum visible gap between appliance faceplates required.

Top

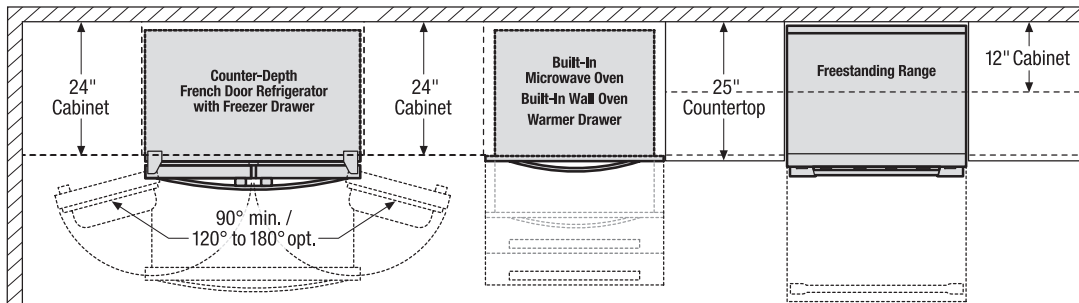

When installing refrigerator adjacent to wall, cabinet or another appliance that extends beyond front edge of unit, 20" minimum clearance recommended to allow for optimum 120° to 180° door swing, providing complete drawer/crisper access and removal.

When installing appliance with sliding drawer or drop-down door directly across from obstructions, provide sufficient clearance for drawer extension or door swing.

Front

To ensure optimum performance, avoid installing refrigeration appliances in direct sunlight or near heat source.

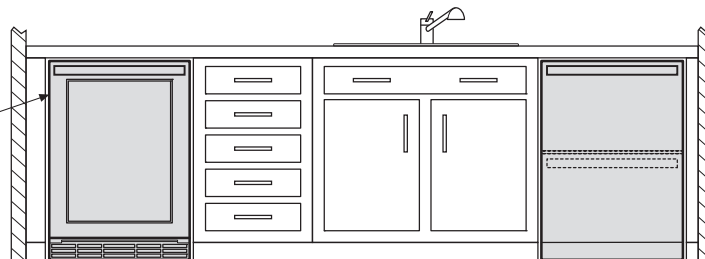

Top

When installing appliance with side-swing door adjacent to wall, cabinet, or other obstruction that extends beyond front edge of appliance, door swing and handle clearance must be sufficient to allow access to appliance interior.

When installing appliance with sliding drawer or drop-down door directly across from obstructions, provide sufficient clearance for drawer extension or door swing.

When installing appliance with sliding drawer or drop-down door adjacent to wall, cabinet, or other obstruction that extends beyond front edge of appliance, allow 2" minimum clearance between drawer or door and obstruction.

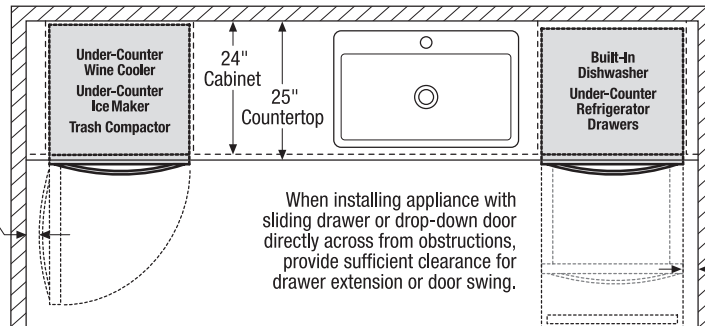

Electrolux Major Appliances, N.A.

USA • 10200 David Taylor Drive • Charlotte, NC 28262 • 1-877-4electrolux (1-877-435-3287) • electroluxicon.com
CANADA • 5855 Terry Fox Way • Mississauga, ON L5V 3E4 • 1-800-265-8352 • electroluxicon.ca

High standards of quality at Electrolux Home Products, Inc. mean we are constantly working to improve our products. We reserve the right to change specifications or discontinue models without notice.

Use these dimensions and clearance instructions for planning purposes only. For detailed installation instructions, refer to installation guide, packed with product, or on the web at electroluxicon.com.

Front

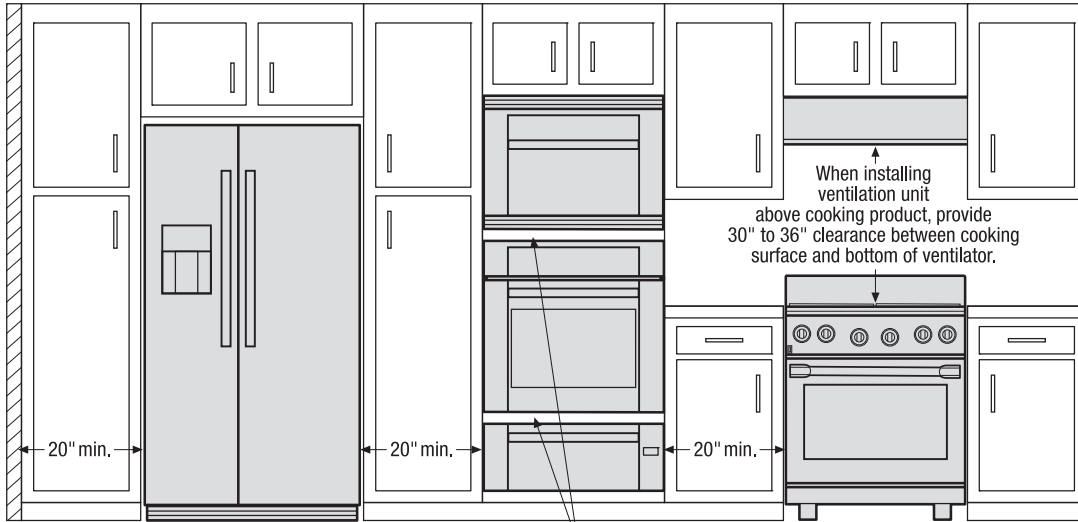

When installing appliances adjacent to each other, 20" minimum distance between each appliance required.

When installing built-in cooking appliances in combination, 2" minimum visible gap between appliance faceplates required.

Top

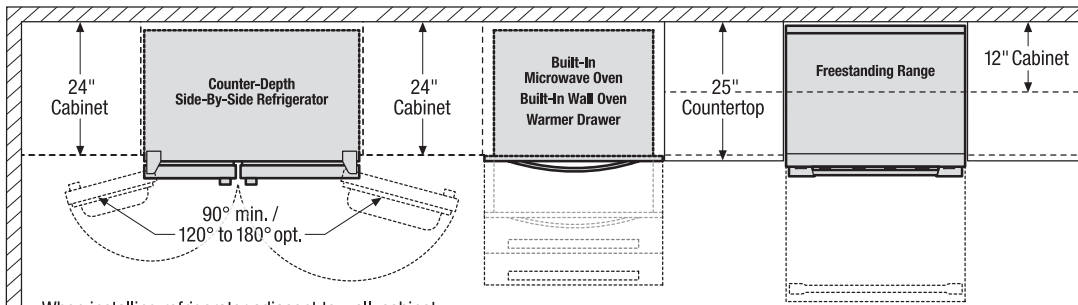

When installing refrigerator adjacent to wall, cabinet or another appliance that extends beyond front edge of unit, 20" minimum clearance recommended to allow for optimum 120° to 180° door swing, providing complete drawer/crisper access and removal.

When installing appliance with sliding drawer or drop-down door directly across from obstructions, provide sufficient clearance for drawer extension or door swing.

Front

To ensure optimum performance, avoid installing refrigeration appliances in direct sunlight or near heat source.

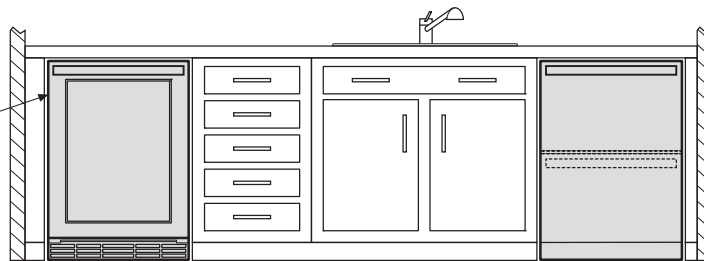

Top

When installing appliance with side-swing door adjacent to wall, cabinet, or other obstruction that extends beyond front edge of appliance, door swing and handle clearance must be sufficient to allow access to appliance interior.

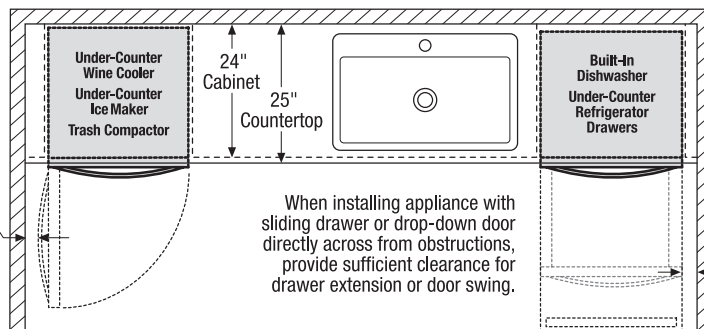

When installing appliance with sliding drawer or drop-down door directly across from obstructions, provide sufficient clearance for drawer extension or door swing.

When installing appliance with sliding drawer or drop-down door adjacent to wall, cabinet, or other obstruction that extends beyond front edge of appliance, allow 2" minimum clearance between drawer or door and obstruction.

Electrolux Major Appliances, N.A.

USA • 10200 David Taylor Drive • Charlotte, NC 28262 • 1-877-4electrolux (1-877-435-3287) • electroluxicon.com
CANADA • 5855 Terry Fox Way • Mississauga, ON L5V 3E4 • 1-800-265-8352 • electroluxicon.ca

High standards of quality at Electrolux Home Products, Inc. mean we are constantly working to improve our products. We reserve the right to change specifications or discontinue models without notice.