

Built-In Coffee Maker

E24CM75GSS designer series



Stainless Steel Dispenser

Dispenser has two spouts, enabling you to dispense two cups of freshly brewed coffee at one time. Spouts adjust in height to accommodate cups of different sizes. Use the articulated frothing steam tube for cappuccino or latte.



Electrolux ICON® Blue Illumination

Signature blue display lighting illuminates the function buttons and brewing compartment with the touch of a switch.



Beverage Dispensing Compartments

Two separate compartments provide for pre-ground flavored/decaffeinated coffee and also whole coffee beans, allowing for customized beverage brewing.



Tamping System

Program the tamping system to work in conjunction with the reverse water flow to bring out the full flavor in espressos.

24" BUILT-IN COFFEE MAKER

Configuration	Water Reservoir
Water Reservoir Capacity	5 Liters (1.3 Gal.)

PRODUCT FEATURES

Stainless Steel European Exterior Style	Yes
Stainless Steel Interior	Yes
Smooth-Glide™ Full-Extension Rails	Yes
Automatic Grinding and Brewing	Yes
Fresh Water Reservoir	Yes
Pre-Ground Coffee Compartment	Yes
Whole-Bean Grinding Compartment	Yes
Dispenser –	
Electronic Touch Control	Yes
Blue LED Serving Display	Yes
Adjustable Height	Yes
Frothing Tube	Yes
Control Panel Options –	
Programmable Drinks	Yes
Volume	Yes
Temperature	Yes
Tamping	Yes
Grind and Brew Time	Yes
Lock	Yes

ACCESSORIES

Cleaning Kit – PN# ACCKIT-24	Optional*
Decalcification Kit – PN# ACCKITA-24	Optional*

SPECIFICATIONS

Overall Exterior Dimensions –	
Height	18-3/16"
Width	23-1/2"
Depth (to Front Panel)	18-3/16"
(with Front Panel in 90° Open Position)	41-11/16"
Electrical – 120V AC/60 Hz/20 Amps	Required
Amps @ 120 Volts	20
Connected Load (kW Rating) @ 120 Volts ‡	1.8
60° Electrical Cable	Included
Power Cord Location	Right Bottom Rear
Shipping Weight (Approx.)	139 Lbs.

* Strongly recommended to help prevent mineral buildup and maintain proper operation of unit.

‡ For use on adequately wired 120V, dedicated circuit having 2-wire service with a separate ground wire. Appliance must be grounded for safe operation.

NOTE: Always consult local and/or national electric codes. Refer to Product Installation Guide for detailed installation instructions on the web at electroluxicon.com.

Specifications subject to change.

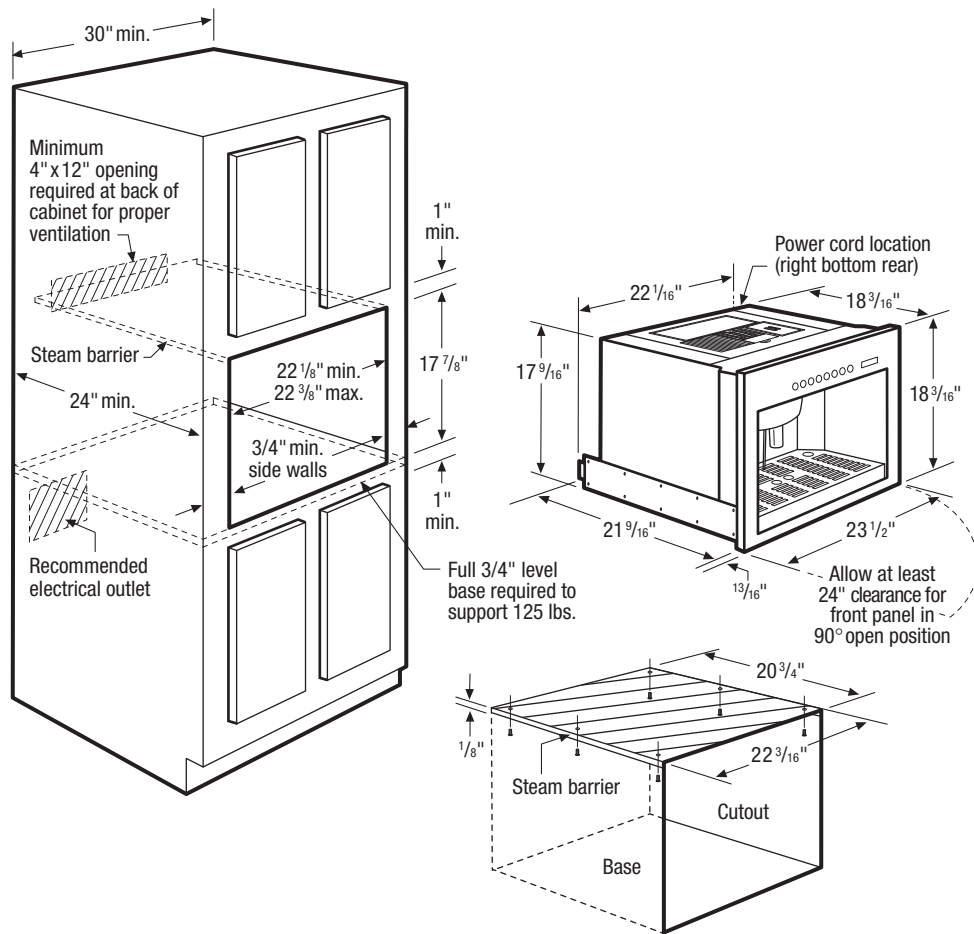

24" Built-In Coffee Maker Specifications

- Product Weight – 110 Lbs.
- Voltage Rating – 120V/ 60Hz/20 Amps
- Connected Load (kW Rating) @ 120 Volts = 1.8kW
(For use on adequately wired 120V, dedicated circuit having 2-wire service with a separate ground wire. Appliance must be grounded for safe operation.)
- Amps @ 120 Volts = 20 Amps
- Recommended electrical outlet location should be in an adjacent cabinet, for accessibility after installation.
- Always consult local and/or national electric codes.
- Unit not approved for use in a freestanding cabinet.
- Full base of solid plywood or similar material required, capable of supporting 125 Lbs.
- Base must be level and front of cabinet square for proper operation.
- Allow at least 24" clearance with front panel in 90° open position.
- To allow for proper ventilation, a minimum opening of 4" H x 12" W required at back of cabinet, near top of cutout.

- Steam barrier supplied for installation.
- Install unit at a safe distance from any heat source, such as other appliances, to avoid excessive rises in temperature.
- A water treatment system may need to be installed for this unit if water hardness level exceeds 4 grains per gallon. A reverse osmosis system is not recommended, since it may reduce water pressure. (Use filtered water only. Do NOT use distilled water.)
- Use of optional Cleaning Kit (ACCKIT-24) and Decalcification Kit (ACCKITA-24) is strongly recommended to help prevent mineral buildup and maintain proper operation of unit.

Note: For planning purposes only. Refer to Product Installation Guide on the web at electroluxicon.com for detailed instructions.

Optional Accessories

- Cleaning Kit – (PN # ACCKIT-24).
- Decalcification Kit – (PN # ACCKITA-24).

Electrolux Major Appliances, N.A.

USA • 250 Bobby Jones Expressway • Augusta, GA 30907 • 1-877-4electrolux (1-877-435-3287) • electroluxicon.com
CANADA • 5855 Terry Fox Way • Mississauga, ON L5V 3E4 • 1-800-265-8352 • electroluxicon.ca